



**9 Empress Way MELTON WEST VIC**

**4**  **2**  **1** 

First home, family home or invest with this sleek design and finished with the highest quality, this spacious residence is going to be hard to go past. Walking distance to Woodgrove shopping centre, Medical centre, all amenities including all levels of schooling, location doesn't get any better than this rare opportunity. Comprising of a lock up garage, 3 bathrooms, 4 generous sized bedrooms with BIR, master with ensuite, large meals/dining area complemented by a spacious open kitchen, enormous living area ticks all the boxes, leading out through your private pergola and entertaining area to an extensive back yard. Includes ducted heating & evaporative cooling, home intercom, fully landscaped front and back gardens. Totally complete to the highest standard, this property is built to impress, don't wait and call today to organise your inspection

**Land Size** : 696 sqm

**View** : <https://www.ypa.com.au/7399238>



### Second Floor

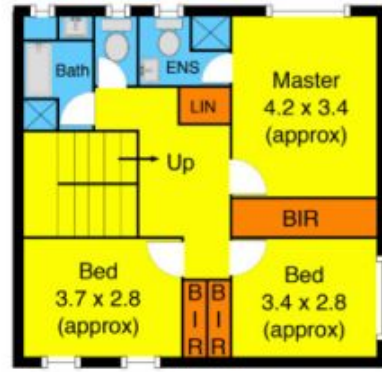

### First Floor

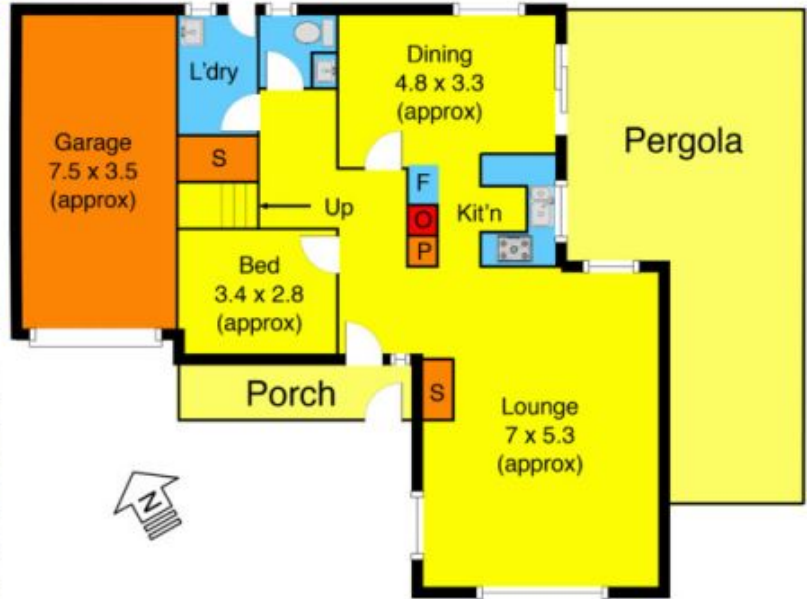

Empress Way